



Upgrade to Heavy Duty Towing

Metro Tow Trucks' INT-16 is the best of both worlds. You can handle big trucks without having to ignore light duty vehicles and passenger cars. This unit will quickly become your favorite truck due to the speed and flexibility to tow just about everything. It's a money maker any way you look at it.

Weight without chassis: 5100 kg

Standard features

- 3546 mm (140") CA standard steel body
- Frame fork holders
- Frame fork racks
- Chain racks
- 4 sets of frame forks
- Chrome door handle
- Driver and passenger side manual controls
- Wheel scoops
- Safety chains

Options

- Wireless Remote Control
- 609 mm (24"), 762 mm (30"), 914 mm (36"), 1219 mm (48"), 1828 mm (72") tunnel box
- Custom length tunnel box
- Extra frame forks
- Wheel lift receivers for single / double tires
- Full recovery tool package
- Custom storage system
- Aluminum / Composite body
- European body style
- Gravel guard undercoating finish
- Front push bumper
- XP, X-shape side puller
- Chrome hand rails
- In cab controls
- European style low under lift
- Full size LED light bar
- LED - working lights, strobe lights, lights inside toolbox
- Custom painting
- Installation services and extended warranty
- Tow operators education & training



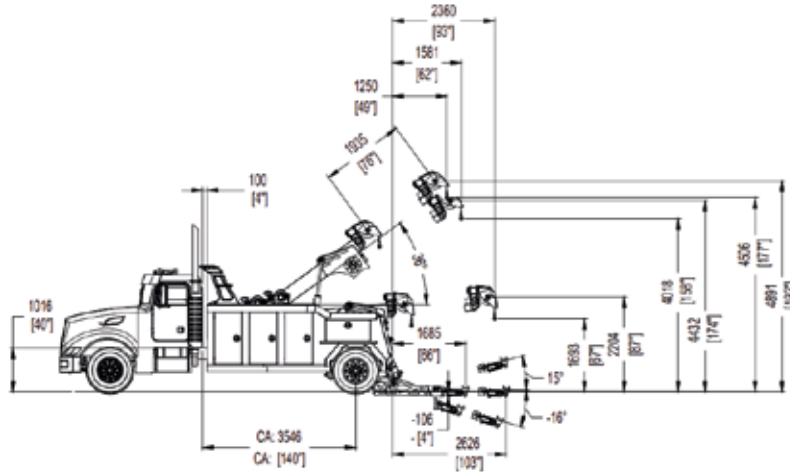

NOTE: Axle configuration is subject to local laws and regulations. All information in this document is for reference purposes only. Optional configuration might be shown.

Underlift Specifications

Retracted capacity on forks	5.4 ton (12,000 lbs)
Retracted distance to the forks	1685 mm (66")
Extended capacity on forks	3.8 ton (8,500 lbs)
Extended capacity on wheel scoops	2.7 ton (6,000 lbs)
Extended distance to the forks	2626 mm (103")
Negative tilt angle	-16°
Tow Rating	14.5 ton (32,000 lbs)

Vehicle Recommendations

Front axle(s) weight (min)	5.4 ton (12,000 lbs)
Rear axle(s) weight (min)	10.4 ton (23,000 lbs)
Recommened GVW	12.3 ton (27,000 lbs) to 13.6 ton (30,000 lbs)
Recommened Tire size	max 255/70 R22.5
Clear CA	3546 mm (140")
Recommened frame height	max 1016 mm (40")

Boom Specifications

Retracted capacity (at 36°)	16 ton (35,200 lbs)
Extended capacity (at 36°)	8 ton (17,600 lbs)
Maximum Lift angle	36°
Maximum Hook Height	4566 mm (177")
Reach Past Tailboard	1581 mm (62")

Winch Specifications

Quantity	2 pcs
Pulling force (on 1st layer)	10 ton (22,000 lbs)
Winch type	Planetary
Cable length	16 mm x 60 m (5/8" x 200')

Notes:

- Some optional equipment may be shown.
- All ratings are based on structural and design factors only. Vehicle chassis capacity and capabilities can vary significantly, affecting the overall performance and rating of the unit. All chassis specifications are minimums, heavier specifications may be required depending on chassis and equipment weights. Please contact your nearest distributor for additional information.

Metro Tow Trucks Ltd. reserves the right to change, improve or modify products, which may change the specifications, models and feature availability at any time without notice and without obligation. Please contact your nearest distributor for additional information.

© Metro Tow Trucks Ltd. All rights reserved. This material may not be reproduced, displayed, modified or distributed without the express prior written permission of the copyright holder. For permission, contact Sales@MetroTowTrucks.com

Metro Tow Trucks

E-mail: Sales@MetroTowTrucks.com

Toll Free (North America): 1-866-924-1675

Direct: +1-613-223-0139

Address: 2759 Lancaster Road,
Ottawa, Ontario, Canada, K1B 4V8